

## Instruction

# TU-UV

## Omniguard portable UV test unit



**Article number:**

**43808-2**



## INSTRUCTION Article number: 43808-2

### GENERAL

The portable UV Test Unit is designed to check the operation of Omniguard UV Fire Detector Heads without the hazard of open flame. The unit meets Canadian Standards Association requirements for use in Class I, Group D hazardous locations.

The unit is composed of a high intensity UV source powered by three nickel-cadmium rechargeable batteries which may be charged from any 120V, 50/60 Hz power source. It is capable of activating the UV Fire Detectors from a distance of 30 feet in direct line of sight, or 26 feet at any angle of 30° from the detector centerline.



### OPERATION

**NOTE:** Disconnect any fire extinguishing circuits controlled by the detector before activating the test unit.

**WARNING!! DO NOT LOOK INTO THE LENS OF THE TEST UNIT WHILE IT IS LIGHTED.**

1. Make sure both end caps are secure with all threads engaged, and all set screws tight.

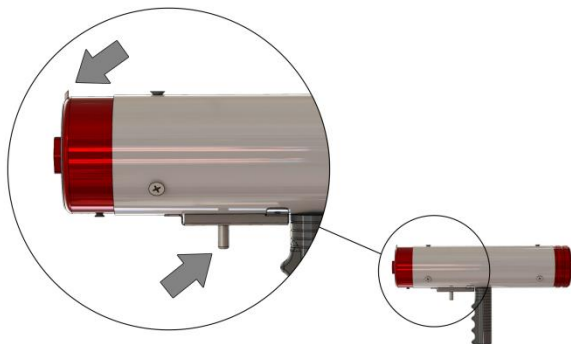

2. While aiming the test unit at the detector, look at the test unit pilot lens located at the top of the front cap and depress the trigger switch. The pilot lens will indicate illumination of the UV source lamp.

3. Standing on the viewing axis of the detector (a line from the center of the detector and at right angles to its front) and at the limit of the protected area, aim the test unit at the detector and depress the trigger switch. The detector should alarm within the time specified for the installation.

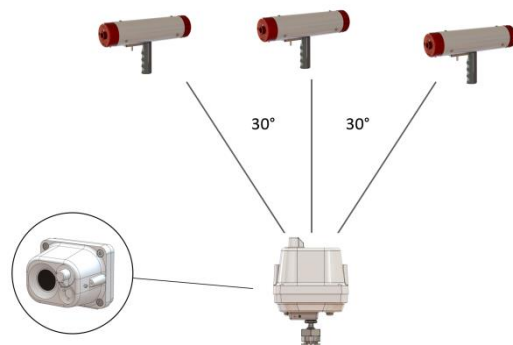

4. Make similar tests from various locations within the protected area, the detector should respond as stated above.

**NOTE:** The portable UV Test unit is designed to check for operation only, not for precision sensitivity testing. This must be accomplished at Firefly AB.



## MAINTENANCE

1. Clean the lens with a soft cloth. Accumulations of dirt or grease will cause faulty operation.

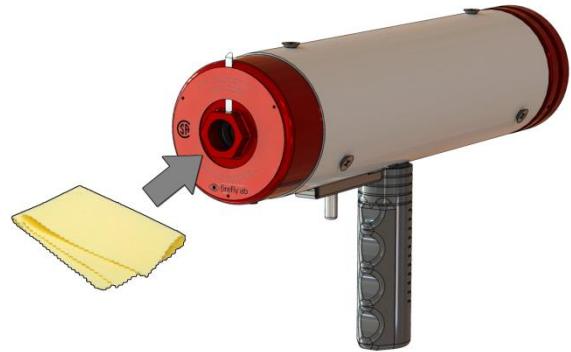

## RECHARGING THE UNIT

1. Loosen the two setscrews and remove the rear end cap.



2. Extend the line cord from its storage in the sleeve and plug it into any 120V, 50/60 Hz power supply. Normally, the unit will be fully charged in 16 hours. If unit is fully discharged, up to 24 hours may be required.



3. Lightly coat the threads of the end cap with antiseize compound, replace it on the sleeve and secure the setscrews. Make sure all threads on the end cap are engaged before securing setscrews.

**NOTE:        ATTEMPT NO REPAIRS ON THE UNIT. A NON-FUNCTIONAL UNIT SHALL BE RETURNED TO FIREFLY AB.**