

WOOD PANEL SOLUTIONS

How to protect your process from fires and dust explosions



REACHING AN EFFICIENT AND SAFE MANUFACTURING PROCESS

The wood panel industry has a longstanding issue with fires. In many plants, fire incidents happen regularly and leads to costly production losses. In some cases, the consequences are even worse, with large damages or personnel injuries.

There are several high-risk areas in the wood panel process where fires or dust explosions may arise. By monitoring and protecting these high-risk areas through an appropriate fire prevention or fire protection system, with a quick response time, fires can be prevented before they cause damages or spread to other areas.

Firefly's unique solutions for a wood panel manufacturing plant combines **fire preventive** and **fire protective** systems for optimal safety. All integrated into one control system.

Don't wait until it's too late – contact Firefly today to learn more about our solutions for the wood panel industry.

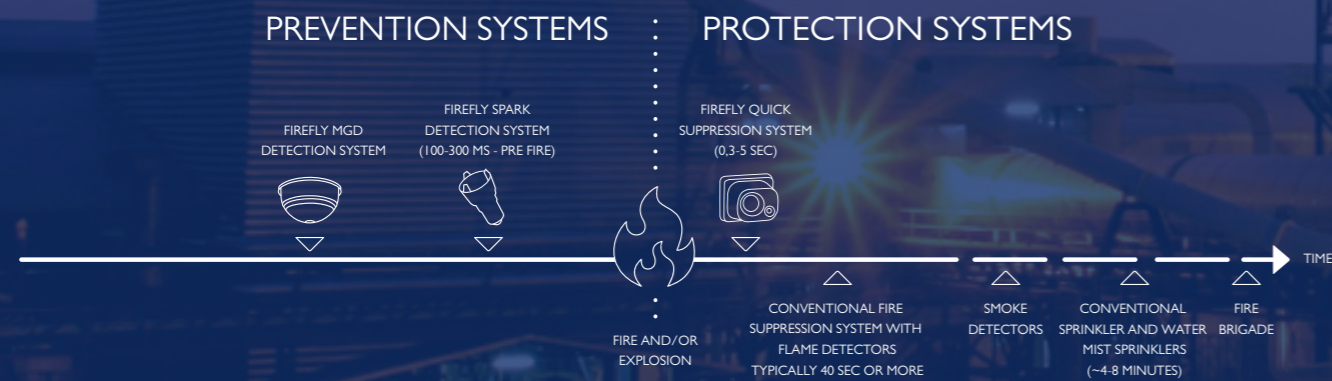

IGNITION TEMPERATURES AND ENERGIES

Many fire problems in the panel industry are caused by friction, wood is a particularly inflammable material.

The friction itself does not generate sparks, but causes hot surfaces and heated material. If the temperature reaches above the MIT (Minimum Ignition Temperature) of the wood dust, an ignition could occur.

The wood in your process can ignite at different temperatures. A wood dust cloud such as in a dust collector, can ignite from 470°C (752°F). However wood dust in a 'layer', such as in a silo or bunker, can ignite from 260°C (482°F). Firefly recognises the differences in ignition temperatures in order to effectively protect your plant against costly fires and dust explosions.

Research* clearly shows that hot (black) particles are more frequent sources of ignition within the process industry than expected. Therefore Firefly has developed a unique and patented technology based on Infrared (IR) radiation detection, which makes it possible to detect and eliminate both sparks and hot particles with temperatures down to 250°C / 480°F, where there is no visible IR/light emitted.

* Prof. Rolf K. Eckhoff, author of "Dust explosions in the process industries" (second edition)

MINIMUM IGNITION TEMPERATURE (MIT) FOR WOOD DUST

Cloud 470°C / 878 °F

Layer 260°C / 500 °F

NOTE THAT A PARTICLE BELOW 650°C IS BLACK.

Source: NFPA (National Fire Protection Association)

” Hot particles can be generated from surfaces that have been heated by friction. A hot particle even the size of a pea may pose a much greater risk than a spark. Even if the temperature of the hot particle is lower than that of a spark, the hot particle will remain dangerous for a longer time.

PROFESSOR ROLF K. ECKHOFF,
Author of "Dust explosions in the process industries"



FIRE PREVENTION SPARK DETECTION SYSTEM

Firefly's Spark Detection and Extinguishing System will, in milliseconds, detect and extinguish ignition sources inside the process, before they cause fire or dust explosion.

Firefly's unique TrueDetect™ technology enables detection of all type of ignition sources such as hot (black) particles, sparks and flames. All our detectors are insensitive to daylight, to avoid unnecessary detections or false positives.

The Spark Detection System is typically combined with a water extinguishing zone, based on Firefly's high-speed and powerful full-cone water spray system. This unique extinguishing concept is designed to cover the entire cross section of a duct or a chute and to penetrate the material flow and air flow.

The Firefly True IR Spark Detection and Extinguishing System is certified according to Factory Mutual (FM)* and Schadenverhütung GmbH (VdS)*.

* FM certificate no. 3060012, Vds approval no. S6990002.



Firefly PowerImpact Extinguishing™

- ⊙ Efficient for extinguishing/cooling of ignition sources in a material flow
- ⊙ Full-cone water spray nozzles
- ⊙ Thoroughly penetrates dense material flow
- ⊙ Activated within milliseconds after detection
- ⊙ Short extinguishing cycles that avoids unnecessary water usage



FIRE PROTECTION QUICK SUPPRESSION SYSTEM

The Firefly Quick Suppression System is designed for extremely quick detection and suppression of flames or fires in and around machinery and in high-risk areas or volumes. The system has been fire tested with the test protocol DFL TMI70307-I261 and verified by the DNV.

Firefly's Quick Suppression System operates with high performance flame detectors and efficient water mist suppression. The Firefly water mist system has remarkable fire suppression capabilities, utilizing a very small amount of water.

The purpose of the Firefly Quick Suppression System is to act quick enough to avoid or significantly reduce damages and production downtime, as well as avoiding a fire from escalating and spreading into other areas. Conventional extinguishing methods, for example sprinklers, need large flames generating a high amount of heat to react and an extensive amount of water is needed to extinguish a fire.



FIREFLY EXIMIO™ – INTELLIGENT SYSTEM ARCHITECTURE

The Firefly EXIMIO™ system is an intelligent and decentralized system with a modular system architecture. Detectors and extinguishing equipment are connected to local EXIMIO™ hubs, thus making cable routing and overall installation more efficient and less expensive. The EXIMIO™ system is modular, where making it easy to add on to the existing system and extend to cover new risk zones if desired.

Operators will control the system via a 12" color touch screen via the IntuVision™ panel, the operators interface, that comes standard in with every Firefly EXIMIO™ system. IntuVision™ is easy to use and includes numerous of features and functions, for example ApplicationView™ is where a drawing of the zone will be shown on the screen.

By using IntuVision™ desktop the customer can connect the system to an external computer, for example in the control room.

The system is OPC-UA compatible, with the availability to integrate the information from EXIMIO™ system into the customer's SCADA system.

The Firefly System can be connected via an Ethernet cable or a modem to enable remote help and service and support.



PARTICLE BOARD MANUFACTURING

By tailoring a fire protection system using fast IR-radiation detection and flame detection in combination with effective water spray extinguishing and water mist suppression, Firefly aims to avoid costly fires and dust explosions in the particle board industry.

EXAMPLE OF RISK AREAS WHICH CAN BE PROTECTED WITH FIREFLY IN THE PARTICLE BOARD INDUSTRY:

- ☑ Drum dryers
- ☑ Belt dryers
- ☑ Screening
- ☑ Dry bin
- ☑ Extraction
- ☑ Filter and silos
- ☑ Sander
- ☑ Press

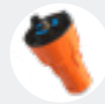

PATENTED TRUE IR DETECTORS

Millisecond detection of hot particles, sparks and flames. Firefly's spark detectors are FM approved and insensitive to daylight.

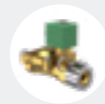

FULL-CONE WATER SPRAY EXTINGUISHING

Powerful extinguishing with a unique nozzle design and placement aimed to penetrate and cover the entire material flow. Activated within milliseconds after detection.



MGD™ DETECTOR

Firefly's MGD™, an intelligent multiple gas detector, commonly known as "electronic nose", is designed to detect the earliest stages of a combustion process, for example the self-heating process of an organic material. The MGD™ can be installed in the top of a silo or in the discharge conveyor from a silo to give an early warning of a combustion process inside the silo.



A UNIFIED CONTROL SYSTEM

Enabling a good overview of all protected zones. Operators will control the system via IntuVision™, an intuitive user interface with a color touch screen, which comes as a standard with in every Firefly System.



FIREFLY PROTECTION SOLUTION FOR PARTICLE BOARD LINE

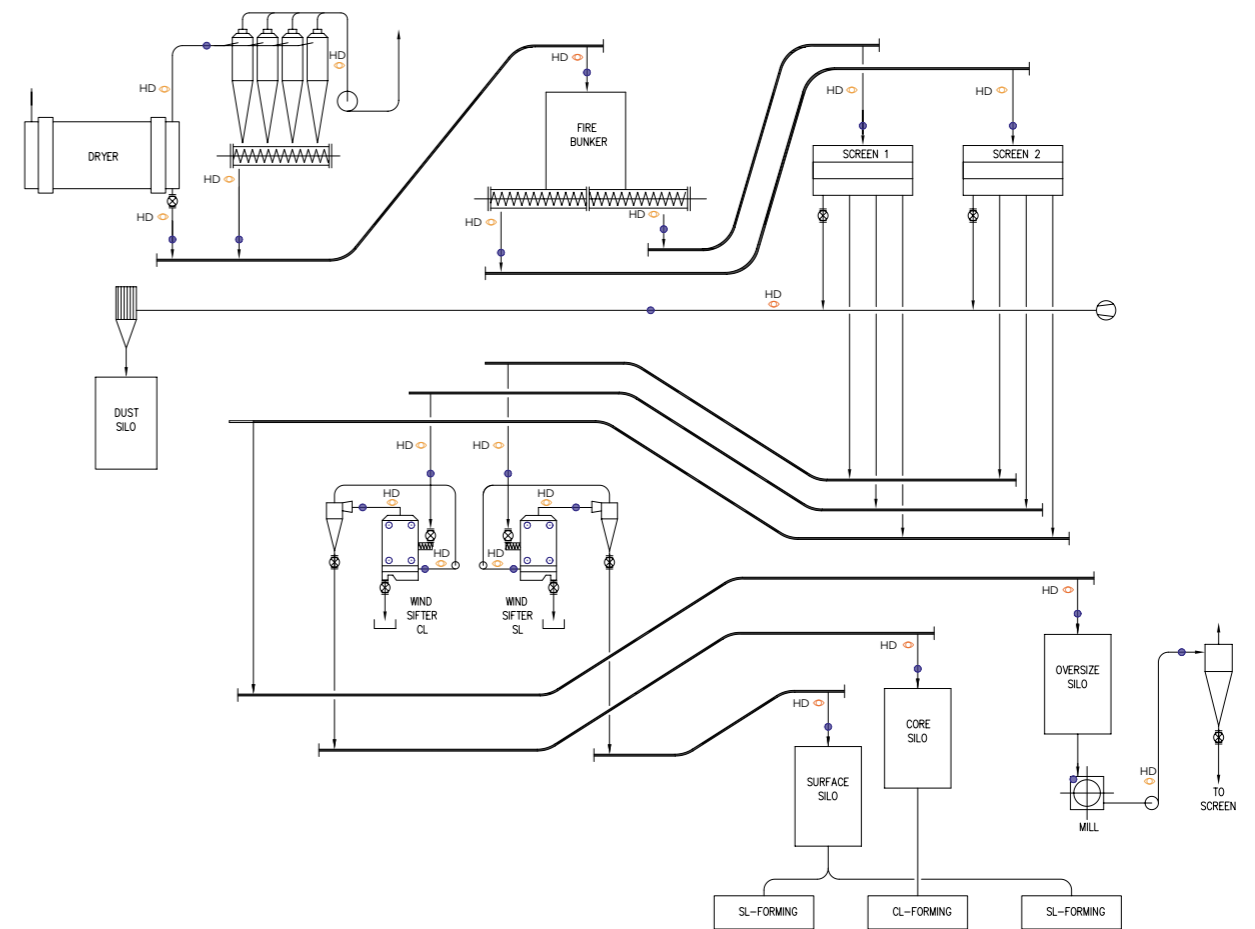

Firefly has a developed concept for the protection of belt dryers. Contact Firefly for more information.

- HD400 Detector - Detects spark and hot particles from 400°C
- HD250 Detector - Detects spark and hot particles from 250°C
- Water spray extinguishing
- Water mist extinguishing

MDF MANUFACTURING

Firefly protects complete MDF lines from dryer to finished board. Firefly's solution can also be used as special protection for wind sifter, dosing bins, forming stations and also for the press.

The solutions are tailored to each customer, so contact Firefly for more information.

EXAMPLE OF RISK AREAS WHICH CAN BE PROTECTED WITH FIREFLY IN THE MDF INDUSTRY:

- ⊙ Dryers
- ⊙ Fiber/dosing bins
- ⊙ Wind sifters
- ⊙ Forming stations
- ⊙ Line extraction
- ⊙ Filter and silos
- ⊙ Sander
- ⊙ Press

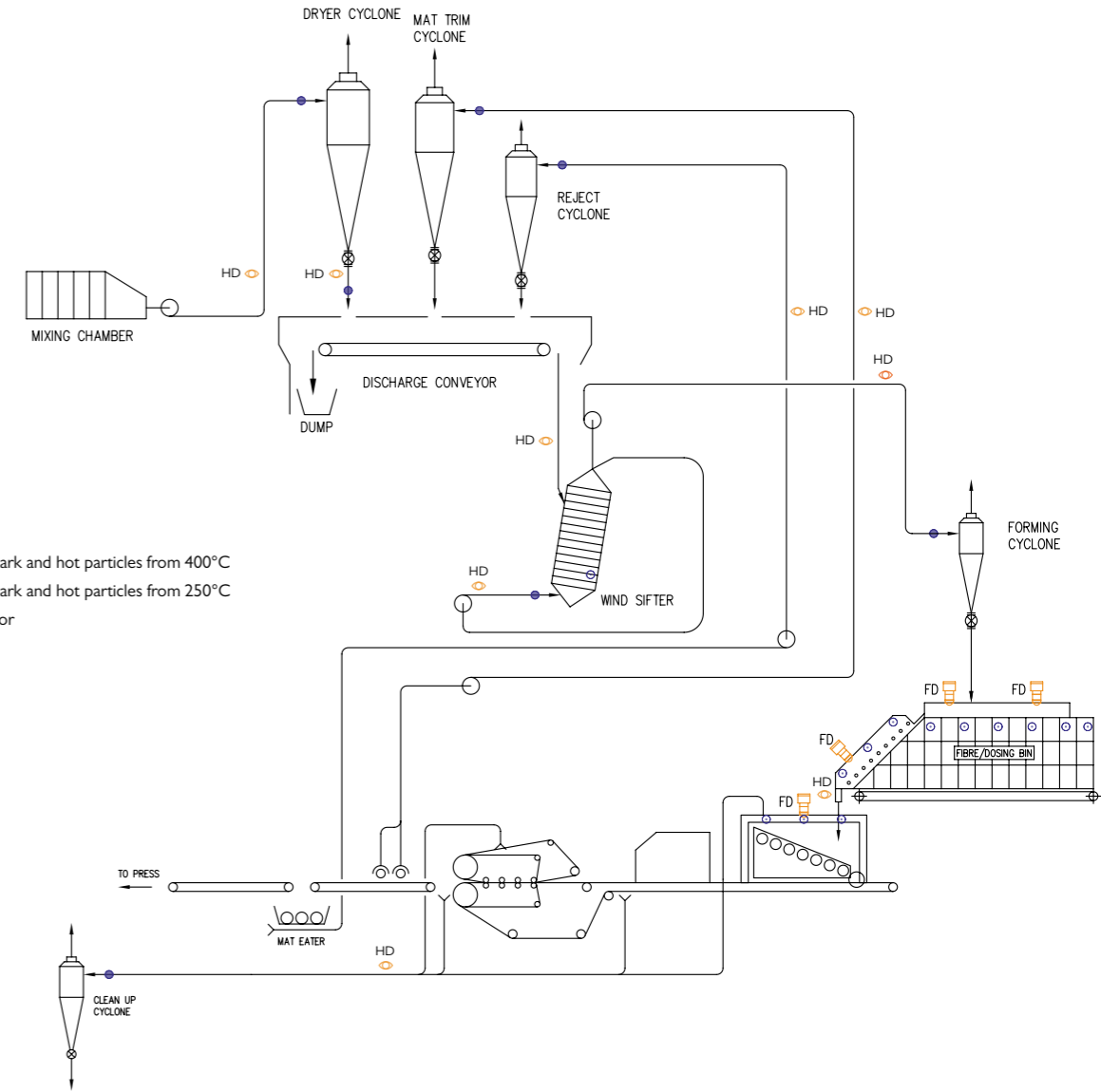

PLYWOOD MANUFACTURING

In the highly demanding environment of plywood manufacturing it is important to ensuring safety and efficiency. Firefly protects complete plywood lines from dryer to finished board.

The solutions are tailored to each customer, so contact Firefly for more information.

EXAMPLE OF RISK AREAS WHICH CAN BE PROTECTED WITH FIREFLY IN PLYWOOD INDUSTRY:

- ⊙ Veenet dryers
- ⊙ Filters
- ⊙ Silo
- ⊙ Sanding
- ⊙ Panel sizing

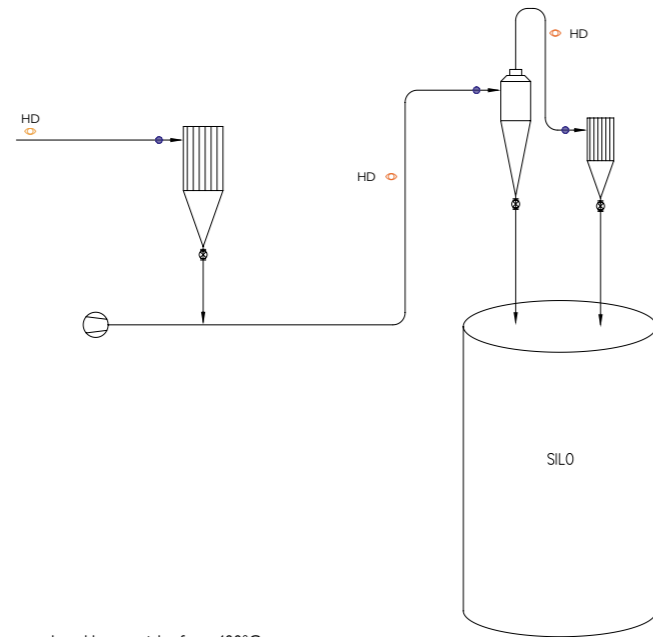

- ⊙ HD400 Detector - Detects spark and hot particles from 400°C
- ⊙ HD250 Detector - Detects spark and hot particles from 250°C
- Water spray extinguishing

OSB MANUFACTURING

Firefly protects complete OSB lines from dryer to finished board. Firefly's solutions can also be used as special protection for dry bins, sifters, conveyors and for the press. The conveyors are protected with Firefly's unique ConveyorGuard™ concept.

The solutions are tailored to each customer, so contact Firefly for more information.

EXAMPLE OF RISK AREAS WHICH CAN BE PROTECTED WITH FIREFLY IN THE OSB INDUSTRY:

- ⊙ Dryers
- ⊙ Screening
- ⊙ Dry bin
- ⊙ Extraction
- ⊙ Filter and silos
- ⊙ Sander
- ⊙ Press

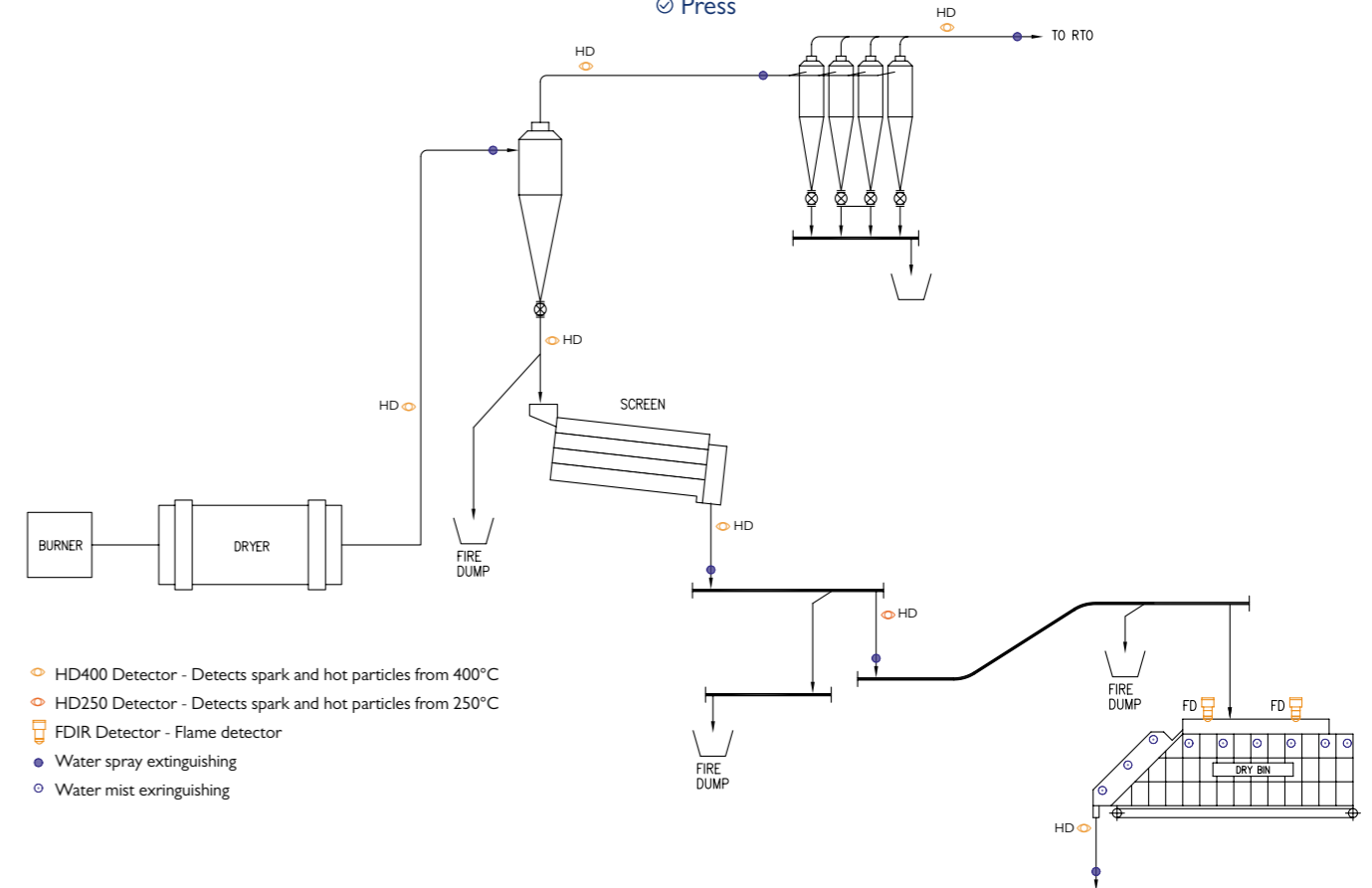

- ⊙ HD400 Detector - Detects spark and hot particles from 400°C
- ⊙ HD250 Detector - Detects spark and hot particles from 250°C
- 🔥 FDIR Detector - Flame detector
- Water spray extinguishing
- Water mist extinguishing

FIREFLY SanderGuard™

The fine dust generated by a sanding machine can, when ignited, give rise to a rapid spread of fire and, in the worst case, a dust explosion. Firefly's SanderGuard™ system solution is designed for all types of sanders. The system includes quick flame detection inside the sanding machine and water mist suppression, providing optimal protection of the sanding machine and reduces the risk of costly production interruptions.

Firefly's SanderGuard™ is designed to early indicate an incipient fire problem in the machine and quickly activate the water mist, before the fire has time to take hold. The solution combines Firefly's spark detection system in the exhaust ducts with Firefly's Quick Suppression System inside the machine itself. The system is adapted to each sanding machine to cover the various risk zones that may occur. It is important to use detectors that are not sensitive to daylight, as a sanding machine is not completely sealed, but light may enter. Firefly's detectors are insensitive to daylight, which minimizes the risk of false alarms and provides safer operation.

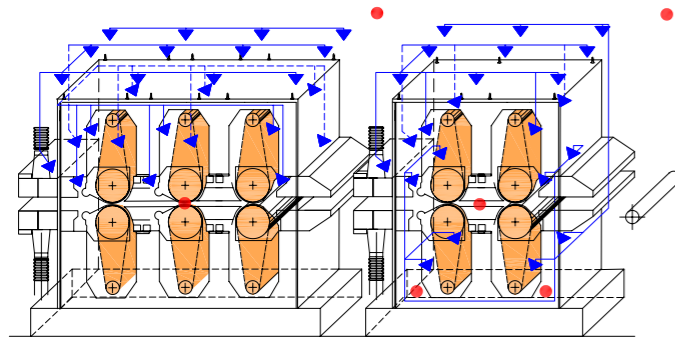

- DETECTION
- ▼ EXTINGUISHING

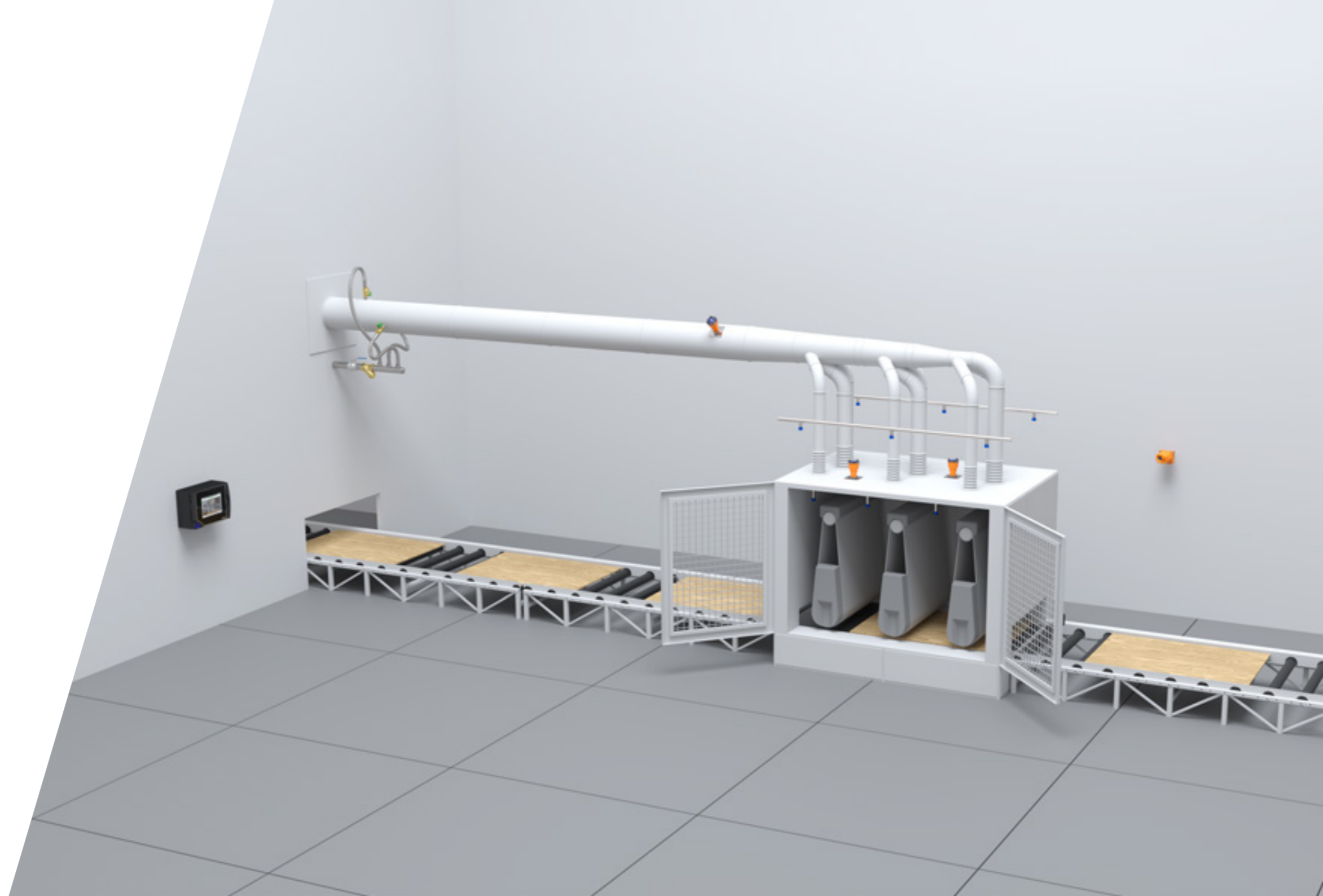

FIREFLY PressGuard® AND OIL PUMP ROOM PROTECTION

It is well known in the wood panel industry that a fire in a press spreads extremely fast. A small flame can, in just a couple of seconds, develop into a large scale press fire with devastating consequences and losses.

Combustible material (wood fibres, dust, various types of oil and wax), oxygen and ignition sources (hot surfaces) are always present in and around a press. Considering that these are the parameters needed to start a fire, the question to be asked should not be if a fire will occur in a continuous press, but rather when.

The Firefly PressGuard® is a Quick Suppression System that consists of a detection and water mist suppression system. The detection system is built on a range of different detectors suitable for usage in different areas of a press, to ensure the best possible accuracy and reaction time. The water mist suppression system uses a lower amount of water to minimize secondary damage and loss.

A PressGuard® system is often complemented with protection of the secondary oil pump room and the channels between the oil pump room and the press. The primary oil pump room can also be protected with the same concept.

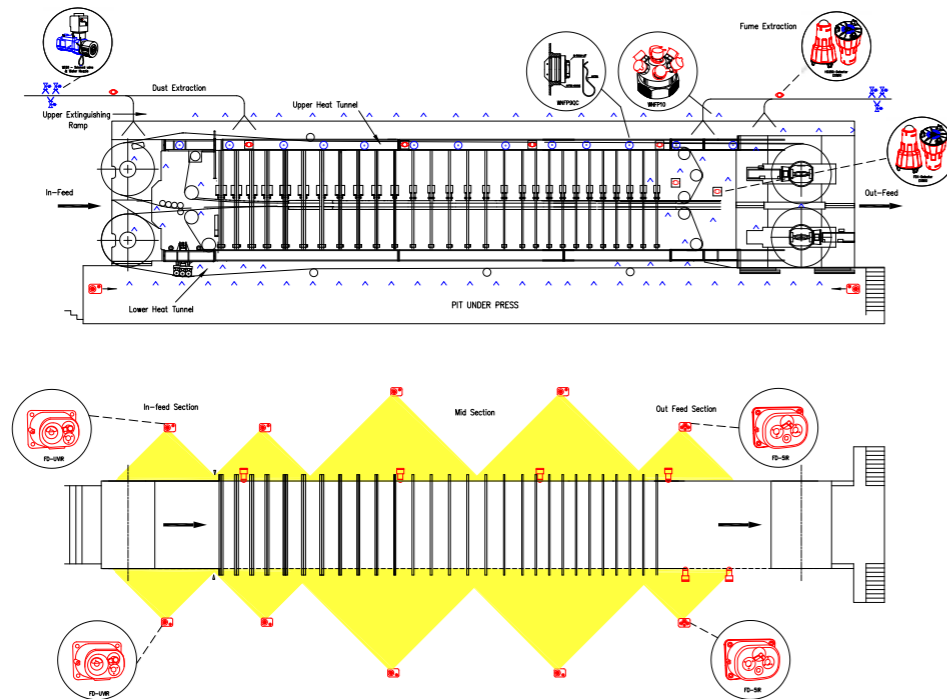

ABOUT FIREFLY

Firefly is a Swedish company that provides industrial fire prevention and protection systems to the process industry worldwide. Since 1973, Firefly has specialized in creating customized system solutions of the highest technical standards and quality. Based on customer needs and research, Firefly has developed and patented products and solutions, creating a unique portfolio of innovative products and system solutions to increase the level of safety and production output.

The Firefly quality management system is certified according to ISO 9001 and EN ISO/IEC 80079-34. Firefly's products hold national and international third-party certifications through FM, VdS, CSA, DNV, LCIE Bureau Veritas, Delta, and RISE among others.

For more information on our certifications and approvals, please visit: www.firefly.se/about-us/certifications-approvals/

Please contact us if you have any questions about fire and explosion risks within your process. Our fire preventive team will be happy to share their knowledge and experience.

AS A FIREFLY CUSTOMER YOU RECEIVE



A partnership with our fire prevention teams around the world.



Technical innovation in fire prevention and protection.



Digital progression based on robust safety systems.



Fire prevention and protection through certified technology.

JOIN THE FIREFLY CIRCLE OF SAFETY

WE HAVE FIREFLY USERS FROM MULTIPLE INDUSTRIES ALL OVER THE WORLD



Firefly users in over 90 countries



■ Firefly users

Firefly's products are available with the following certifications and approvals:



For information on the certifications and approvals each product holds please visit:

www.firefly.se/about-us/certifications-approvals/



Firefly AB
Phone +46 (0)8 449 25 00
info@firefly.se | www.firefly.se

Firefly Wood Panel Solutions 2.2 EN
© Firefly AB (2024)

